



## CUDA M1500 Military Catalog

Advancing the capabilities  
for Maritime Forces

4433 Russell Rd ste 106  
Mukilteo WA, 98275 USA  
[www.dive-xtras.com](http://www.dive-xtras.com)  
[info@dive-xtras.com](mailto:info@dive-xtras.com)  
T 425.493.9600



# Dive Propulsion Devices



For the past 4 years Dive Xtras Inc. has been producing top of the line diver propulsion devices for the diver looking for lightweight high performance. Traditionally single person DPD's have had significant drawbacks, either being heavy lead acid powered giants with poor run times, or based on recreational toys. More modern military vehicles have overcome these drawbacks but at the expense of size and weight, creating large vehicles over 150lbs/68kg.

Dive Xtras has chosen to improve on the small compact single person DPD, with all its benefits of portability, redundancy and cost effectiveness, but improve its performance using modern technologies to match that of larger vehicles. Technology has made several key advances over the last few years that has enabled Dive Xtras, almost uniquely in the industry, to make huge leap forwards in performance:

Brushless motors offer smaller packages with more efficient cooling and higher reliability due minimal moving parts.

Compact motor controls allow us to add speed controls to vastly improve usability.

Battery capacity has leapt forward from lead acid at 30-40wh/kg to current lithium cells exceeding 160wh/kg, 4 times the power for the same weight.

Computer aided design and finite element analysis allow the design of vehicles optimized for size and weight without compromising strength.



# Military Application

The use of high performance single person DPD's also offers several benefits that can be utilized by mission planners:

## Load Carrying Capacity

All Dive Xtras vehicles are equipped to tow neutrally buoyant equipment using sub-surface capable dry bags. (Weight is irrelevant if it is neutrally buoyant) This equipment is towed without load on the diver minimizing fatigue.

## Fatigue Free Transport

Using the Dive Xtras 3 point harness, divers can transport with minimal physical stress. All loads pass through the harness into the diver ensuring he arrives at his destination at maximum capability. The lightweight nature of Dive Xtras vehicles also ensure that entry and exit from the water can be accomplished easily with minimal additional effort due to the vehicle.

## Scalability

Dive Xtras vehicles can be easily be scaled to meet mission objectives. Minimal use may start with single units within a team to support heavily loaded swimmers through multiple units per swimmer to support extended range missions over 8 hours or 10 miles.

## Redundancy

All Dive Xtras vehicles are capable of towing 2 divers, this means a team can deal with loss/damage/failure internally, quickly and easily, completing the mission as planned. The vehicles are also small enough additional vehicles can be carried within the team to supplement the primary vehicles if needed.

## Maximize Deployability from Multiple Platforms

All Dive Xtras vehicles can easily be carried by one person. This makes them deployable from almost any craft capable of carrying the diver. The CUDA M1500 only weights 54lbs (24kg) and has a potential range of 10.9 miles (20km).

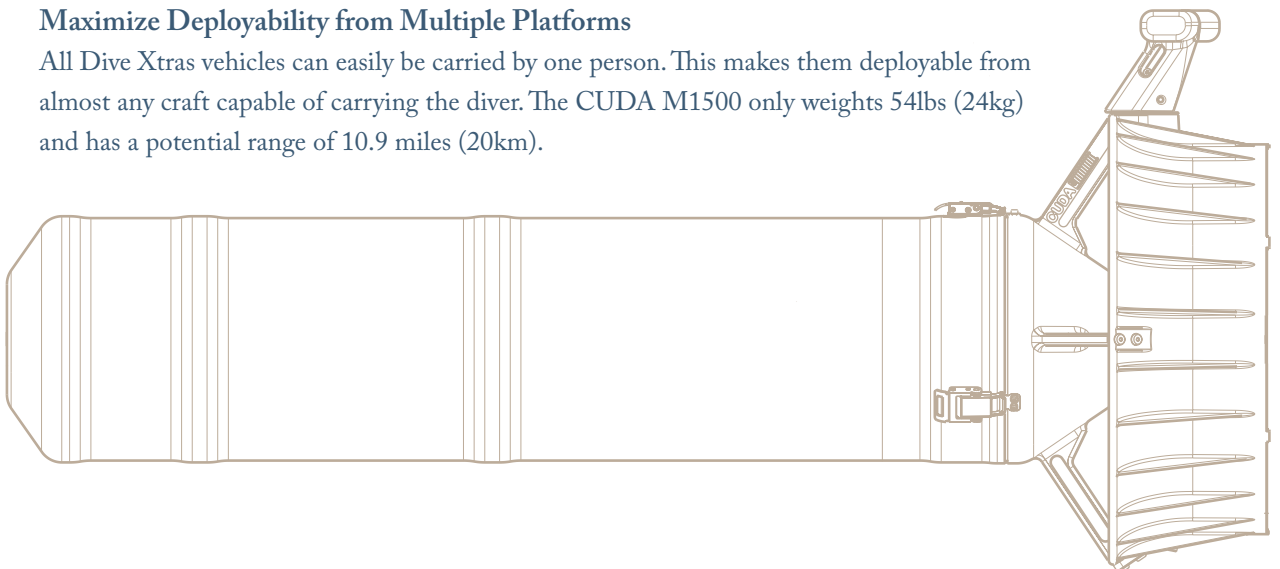



# CUDA M1500

The CUDA-M 1500 is a compact lightweight powerful diver propulsion device (DPD). It offers combat swimmers a lighter more deployable alternative to larger 2 man vehicles whilst still providing the power to tow large equipment loads, with over the horizon deployment capability from small craft.

Capable of transporting 1 fully equipped combat swimmer at speeds up to 4 knots, with a range of over 10 nautical miles. Capable of transporting 2 swimmers if the need arises.

Transports the combat swimmer and up to 200lbs of neutrally buoyant cargo. Cargo load does not affect the swimmer.

Compact powerful package easily deployable from any combat swimmer platform. 54lbs/24kg ready to dive.

Aluminum construction with 600ft depth rating provides unparalleled robustness.

Patented state of the art Lithium ion battery technology from the world leaders in large long life lithium packs, gives long term reliability.

Cost effective NiMh battery options available for training purposes.

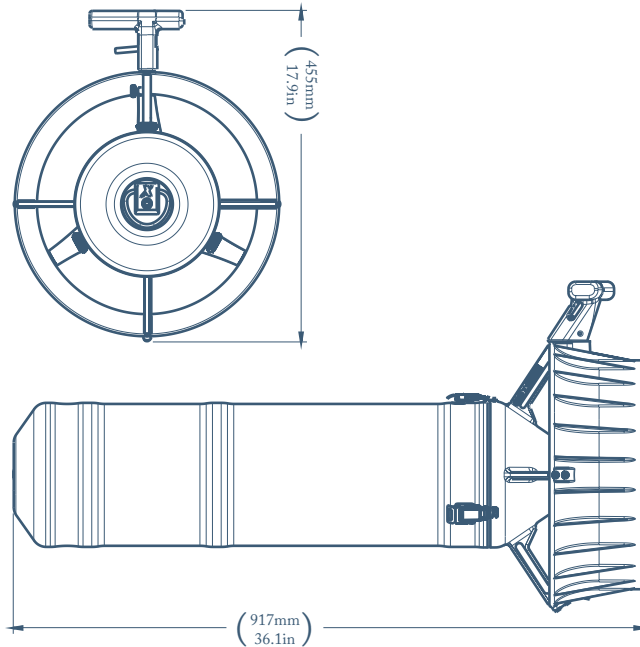

## General

Weight	54lbs 24kg ready to dive
Cargo capacity:	1m <sup>2</sup> (35 cu/ft) or 200lbs of neutrally buoyant cargo, whichever is greater. (Cargo and configuration of cargo will affect speeds and range)
Operating Depth:	600 FSW (180m)

## Performance:

Run time at low cruise speed	(1.3kts 2.4km/h) 501min
Run time at high cruise speed	(2.2kts 4km/h) 92min
Range at low cruise speed	(1.3kts 2.4km/h) 10.9nm 20km
Range at high cruise speed	(2.2kts 4km/h) 3.3nm 6.1km

(Performance based on typical combat swimmer, actual performance may be better or worse depending on skill level)

## Battery

Chemistry:	Lithium ion
Protection:	Additional waterproof barrier once installed. Internal over charge/discharge. Short circuit.
Nominal capacity:	1580Wh (39Ah)
Nominal Voltage:	40.7 V DC
Cycle life:	250 cycles at 75% capacity
Shelf life:	3+ years @ 70deg F with negligible capacity loss.

## Charging

Charge Time:	10 hours from full discharge.
	Input Power: 110-240VAC 50/60Hz





# CUDA M1500 Package



## Kit Includes:

- 1 1 Tail Assembly
- 2 1 Battery
- 3 1 Military Spares kit
- 4 1 Dual Gauge Mount
- 5 1 Battery Charger
- 6 1 Hull
- 7 1 Crotch Strap
- 8 1 Military Grade Hard Case





# Features in Detail

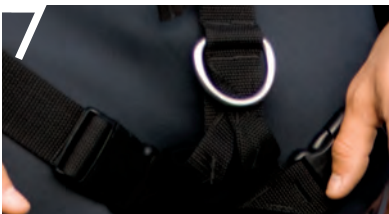
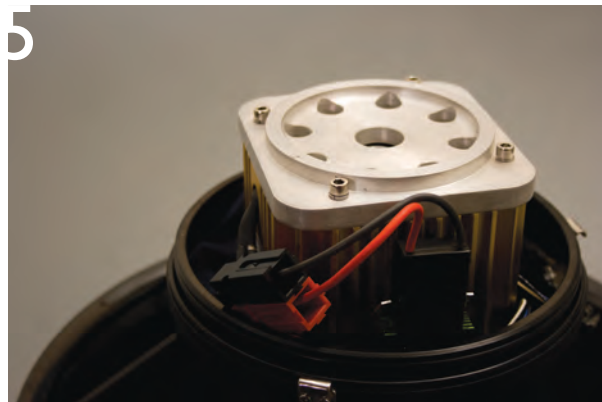
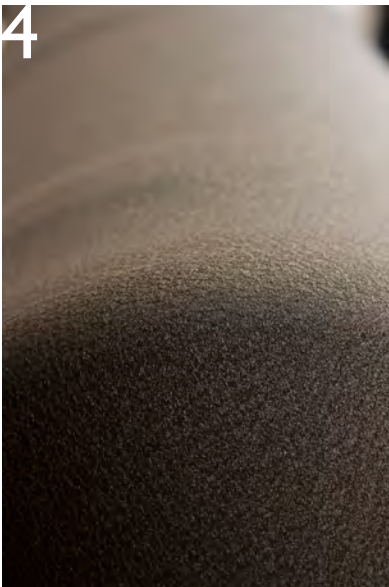

- 1** Robust construction with an all aluminum (6061 T6) body and a 600ft depth rating. Simple design with only two external penetrations. To most users this equates to a vehicle that will cope with the harshest use, day after day, with minimal maintenance.
- 2** Dual gauge mount console places key information, depth, direction and time in front of the diver where he can easily use it for accurate mission execution.
- 3** Shrouded 14in propeller makes the vehicle efficient and quiet. Propeller has a variable pitch mechanism allowing fine tuning of thrust.
- 4** Corrosion resistant coatings combine to offer low reflectivity, abrasion resistant finish. Coating is a combination of clear Iridite base under a powdercoated crinkle finish.
- 5** High efficiency brushless motor provides over 1Hp to the propeller. Brushless motors offer reduced part counts for low maintenance and more efficient cooling.
- 6** Trigger controls eight gear electronic clutch for on the fly speed adjustment. Clicking the trigger once lowers the speed, two clicks increases speed.
- 7** With the 3 point harness, divers can transport with minimal physical stress. All loads pass through the harness into the diver ensuring maximum capability on arrival.



# Options



Dive Xtras recommends that ALL customers receive a minimum of operator training before using dive Xtras DPD's.

- 1 Operator training: Comprehensive 3 day class for operators that covers using the vehicle and basic maintenance in the field. Conducted at the customers facility with Dive Xtras Staff.
- 2 Advanced Operator Training: 5 day class for operators (2 days if following Std operator training) covering more advanced DPD skills such as navigation and dealing with loss/damage failures during a mission. Conducted at the customers facility with Dive Xtras Staff. Course can be customized on request to focus on specific topics.



- 3 Advanced Maintenance and Repair: 2 day class for technicians focusing on all aspects of maintenance, repair and troubleshooting required to keep vehicles in operation long term. Conducted at the Dive Xtras Facility or Customers facility on request.

- 4 M1500 battery: Additional battery for the vehicle, especially useful in training to reduce down time due to battery charging.

- 5 Battery Hard Case: Provides extra protection when transporting batteries out of the vehicle.

- 6 Long Term/Custom Spares Kits: The supplied spares kit provides all the consumables required to operate the vehicle for approximately 1 year. For long term maintenance custom kits can be assembled to suit your units requirements.



- 7 Cuda 650 NiMh spare battery: Low cost battery option for training or short missions.

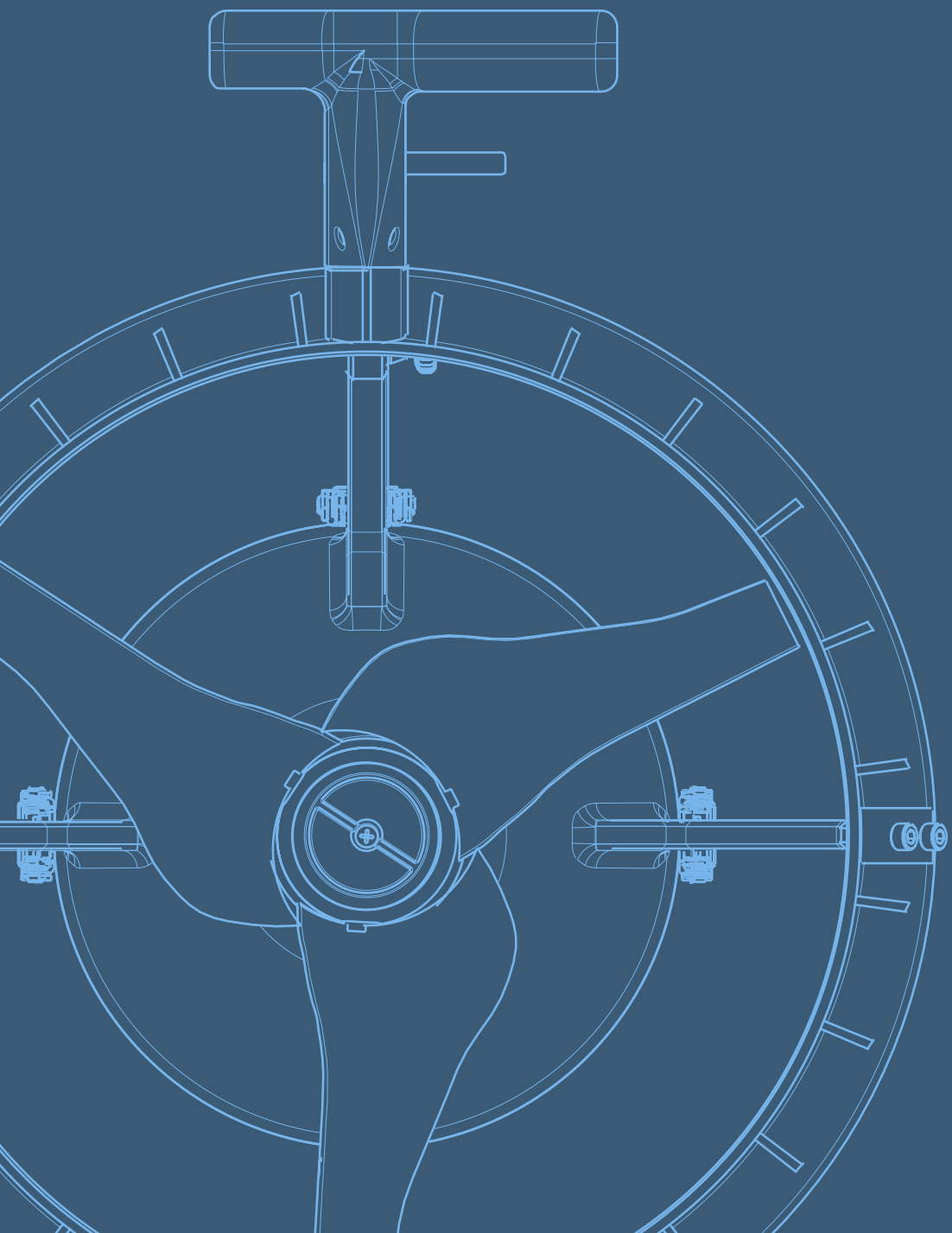

4433 Russell Rd ste 106  
Mukilteo WA, 98275 USA  
[www.dive-xtras.com](http://www.dive-xtras.com)  
[info@dive-xtras.com](mailto:info@dive-xtras.com)  
T 425.493.9600